

# DIN 105 TSL

## Digital dynamometer with load cell Suitable for cranes

### Features

- Capacities: 3200; 6300; 10000; 25000; 35000 kg
- Display: 5 digit Led height 25 mm
- Supply: rechargeable battery set
- Autonomy: 36 hours
- Main Functions: tare reset, peak  
Settable Auto Off and stand by  
Digital filter  
display brightness
- Materials: case in polycarbonate  
Load cell in galvanized alloy steel
- Fittings: eyebolt top and  
revolving hook lower
- Accuracy: 0.1% f.s.
- Overload: 120% f.s.
- Safety factor: 5
- Working Temperature: -10 ÷ +60 °C
- Protection Degree: IP 55

### DIN 105 TSL RADIO:

Version with wireless weight transmission to remote receiver (see catalogue of remote receiver)

### Standard Equipments

- Remote controller
- Battery charger: 220 V 50/60 Hz
- Calibration certificate
- Declaration CE
- User manual

### On demand fittings

- Shackles; revolving hook
- Bag
- IP66 execution

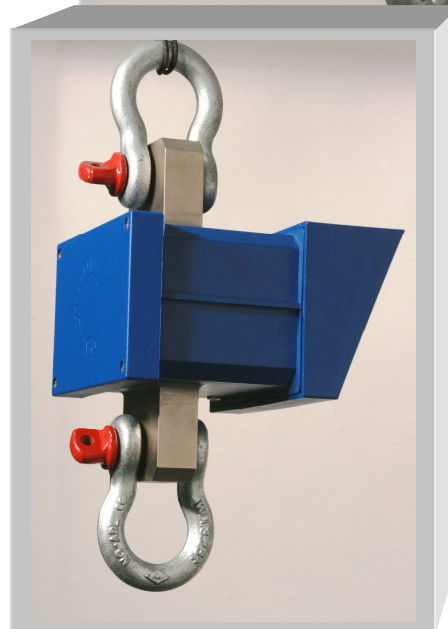

**CAMI S.r.l.**

**MEASUREMENT INSTRUMENTS**

Via Alessandrini, 2 - 20090 TREZZANO S/N (MI)

Tel. 02 4840 0166 - Fax 02 4840 1905

[www.cami-it.com](http://www.cami-it.com) - e-mail [info@cami-it.com](mailto:info@cami-it.com)

# DIN 105 TSL

## Digital dynamometer with load cell Suitable for cranes

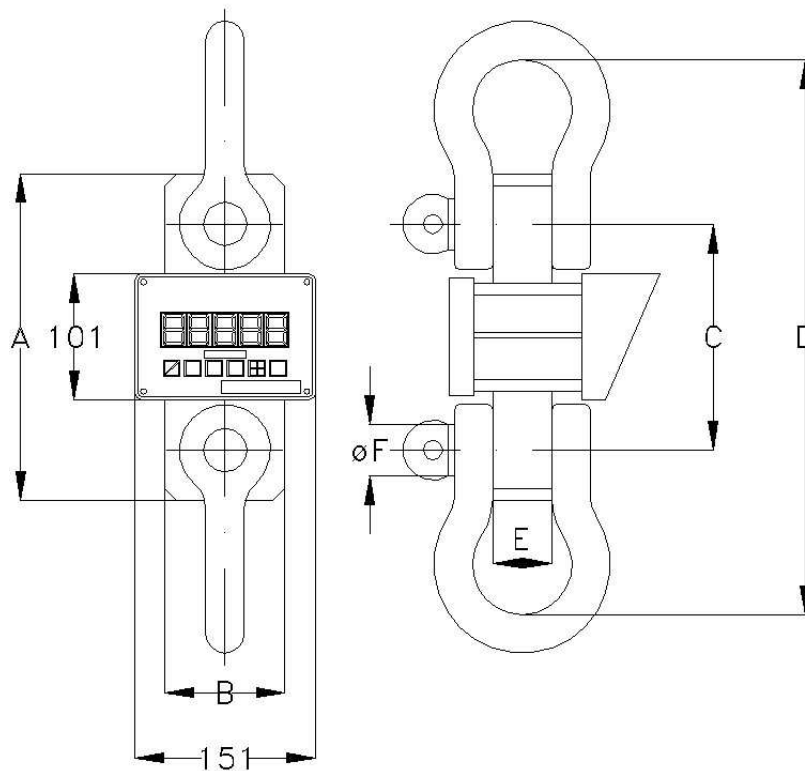

Capacity [kg]	Division [kg]	Weight [kg]	Dimensions [mm]					
			A	B	C	D	E	F
3200	1	3,2	206	70	166	306	25	20
6300	2	4,8	224	70	166	360	40	26
10000	5	8,6	270	100	188	462	49	36
25000	10	12,8	370	100	257	665	49	56
35000	20	13,0	370	100	257	708	79	59

**CAMI S.r.l.**

**MEASUREMENT INSTRUMENTS**

Via Alessandrini, 2 - 20090 TREZZANO S/N (MI)

Tel. 02 4840 0166 - Fax 02 4840 1905

[www.cami-it.com](http://www.cami-it.com) - e-mail [info@cami-it.com](mailto:info@cami-it.com)